

# PRISMATIC POST TOP

The Lindy® Model 424



Model 424 Type V

## Description

LexaLite's The Lindy Model 424 refractor and prismatic top feature a traditional turn-of-the-century shape and state-of-the-art photometric performance. The 424 Series is available in IES Type III and Type V distributions, and will classify as medium, non-cutoff or semi-cutoff, depending upon lamp type and lamp center location. The assembled refractor bottom and top are 15.9" in diameter, 23.16" high and are available in 8" or 9" diameter fitters for pole heights 10'-20'. Both the refractor and prismatic top are available in polycarbonate, for use in areas where breakage is a concern; and HID acrylic and acrylic Moon Glow white (diffuse acrylic), for high efficiency in general lighting applications. Both components can be produced in high heat acrylic and impact acrylics.

## Application

LexaLite's Model 424 refractor and Model 424 prismatic top are for use in parks, along walkways, roadways or areas where a distinctive nostalgic theme is prevalent.

## Lamp Data

The Model 424 is capable of being used with 150W diffuse HPS or 175W coated MH vertical base down lamps and can be used with up to 250W lamps. Luminaire design, reflector configuration, lamp position and ambient temperature will affect the inside surface temperature. Thermal tests should be conducted on each luminaire design to confirm appropriate lamp size for the application.

## Ordering Information

Please call 800-228-5275 or 231-547-6584 for price and delivery. Typical lead time is four to six weeks.

## Service Life

The service life of acrylic refractors is virtually unlimited when used within the recommended temperature limit. Acrylic versions are covered by our 10 year limited warranty.

## Notice

LexaLite assumes no responsibility for suitability of luminaires and applications. The use of refractors at excessive temperatures with high UV output light sources will cause degradation of the material.

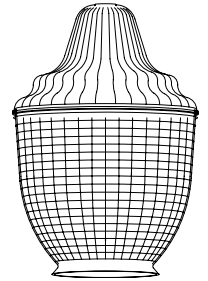

## Model 424

23.16" high  
15.9" diameter

NOSTALGIC POST TOP  
FOR STREET AND  
AREA LIGHTING

TYPE III AND TYPE V  
DISTRIBUTIONS

Model 424 Type III  
Medium non-cutoff  
81.25% Efficiency  
14.57% Uplight with LiteLid®  
66.68% Downlight

Materials: Acrylic,  
Acrylic Moon Glow White  
and Polycarbonate



**A.L.P.**  
LIGHTING COMPONENTS, INC.  
WEB SITE: [WWW.ALPLIGHTING.COM](http://WWW.ALPLIGHTING.COM)

**LEXALITE**

# Model 424

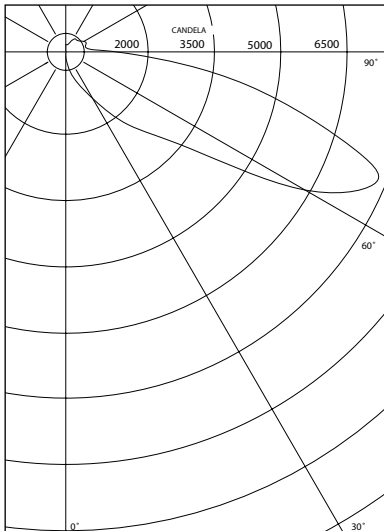

Report Number: ITL48610  
 Total Luminaire Efficiency = 81.25%  
 IES Classification: Type III, Medium, Non-Cutoff

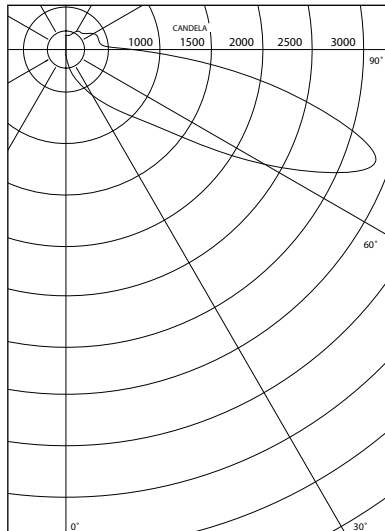

Report Number: ITL48623  
 Total Luminaire Efficiency = 81.72%  
 IES Classification: Type V, Semi-cutoff

## Photometrics:

The Model 424 Type III, coupled with the perforated LiteLid, Model 424 top and a 150W diffuse HPS lamp, produces 7792 candela at 67.5° vertical and 73.3° lateral (ITL48610). The Model 424 Type V, coupled with the perforated LiteLid, Model 424 top and a 150W diffuse HPS lamp, produces 3337 candela at 70° vertical (ITL48623). Both the Type III and V distributions are optimized with diffuse HPS and coated MH lamps. Use of clear lamps may produce reduced uniformity. Individual luminaire performance depends on the lamp center position and the reflector design chosen. Each luminaire design should be individually tested for proper classification. Please call for additional photometric data. Light center location for the Type V shown in report ITL 48623 is 2.7" down from upper rim.

## Accessories

**LiteLid®** LiteLids should be utilized in light pollution-sensitive areas to redirect potentially wasted uplight into increased downward efficiencies. The LiteLid® allows just enough uplight for a pleasing glow. LiteLids are patented, aluminum reflectors which fit between the top and bottom components.

**4245P** Perforated LiteLid

**4245N** Non-perforated LiteLid

**Stainless Steel Clamp Band** For attachment of top.

**Finials** Available in either black flame or black spike design.

**Neck Ring** Protects fitter from metal screws.

## Materials

Clear acrylic: Molded in Underwriters Laboratory (UL) recognized Altuglas International Plexiglas® V-825-HID, Lucite International Inc. Perspex® CP-75-HID, Plaskolite Optix® CA-75HID or CYRO Acrylite® S-10-453.

Acrylic Moon Glow white: Molded in a PMMA resin with a customized pigment additive.

Clear polycarbonate: Molded in UL recognized Bayer lighting grade polycarbonates including Makrolon® LTG 3123, Makrolon® LTG 2623, or GE Lexan® grade 243. Lexalite's proprietary treatment to retard yellowing in ultraviolet environments, UvaLex®, is optional on these polycarbonate refractors.

Please visit our web site for the most current material specifications. When using an acrylic Model 424, the surface temperature of the refractor should not exceed 80°C. When using a polycarbonate Model 424, the surface temperature of the refractor should not exceed 90°C.

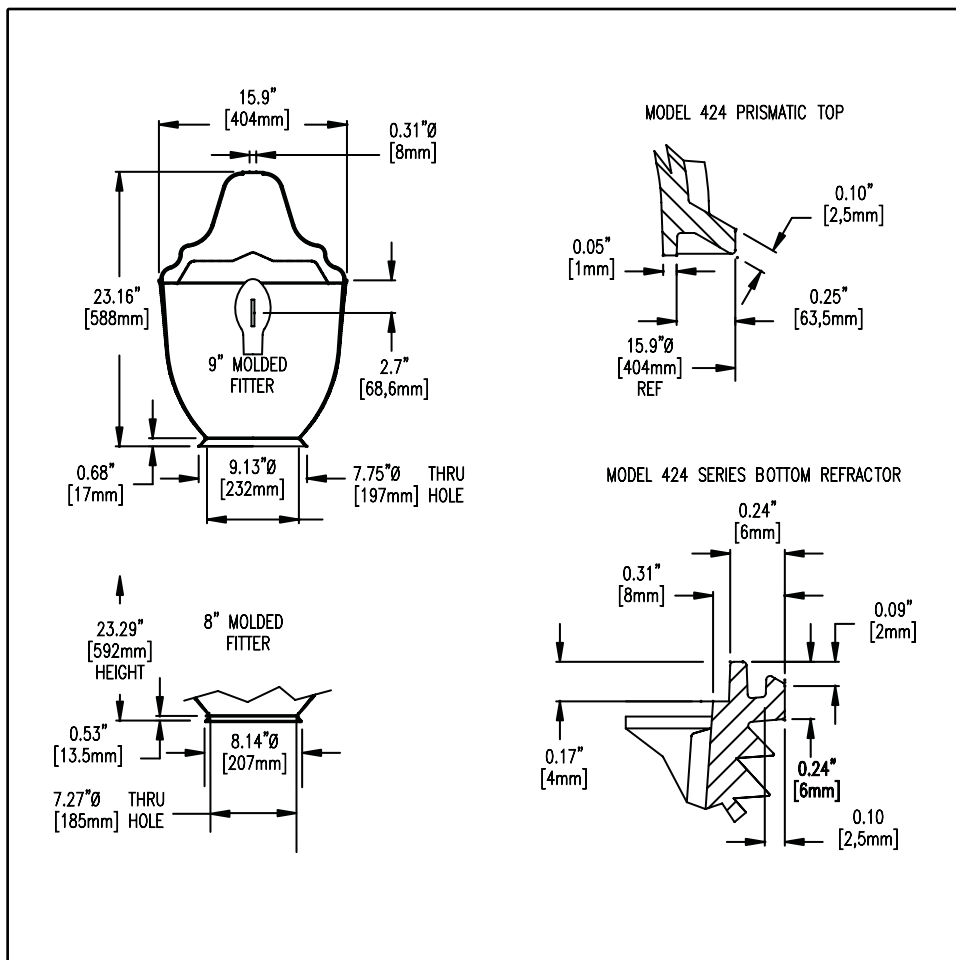

This drawing is for reference only. Actual part dimensions will vary. Customer is urged to review actual samples to confirm fit and function. All specifications and dimensions are subject to change without notice.

# PRISMATIC POST TOP

The Lindy® Model 425



Model 425 Type V

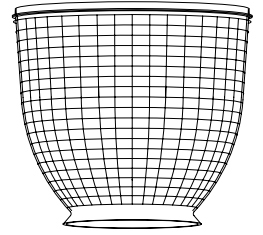

## Model 425

14.33" high  
15.5" diameter

NOSTALGIC POST TOP FOR  
STREET AND AREA LIGHTING

TYPE III AND TYPE V  
DISTRIBUTIONS

Model 425 Type III  
Medium non-cutoff  
83.17% Efficiency  
16.51% Uplight with LiteLid®  
66.5% Downlight

Materials: Acrylic,  
Acrylic Moon Glow White  
and Polycarbonate

## Description

LexaLite's Model 425 refractor is designed to mate with your own top and can be used in parks, along walkways, roadways or areas where a distinctive nostalgic theme is prevalent. It features a traditional turn-of-the-century shape, and provides state-of-the-art performance. This refractor bottom is 15.5" in diameter, 14.33" high and is designed to be used with poles 10'-20' in height. This refractor is available in polycarbonate, for use in areas where breakage is a concern; and HID acrylic and acrylic Moon Glow white (diffuse acrylic), for high efficiency in general lighting applications. This component can also be produced in high heat acrylic and impact acrylics.

## Application

LexaLite's Model 425 refractor is for use in parks, along walkways, roadways or areas where a distinctive nostalgic theme is prevalent.

## Lamp Data

The Model 425 is capable of being used with 150W diffuse HPS or 175W coated MH vertical base down lamps. The Model 425 can be used

with up to 250W lamps. Luminaire design, reflector configuration, lamp position and ambient temperature will affect the inside surface temperature. Thermal tests should be conducted on each luminaire design to confirm appropriate lamp size for the application.

## Ordering Information

Please call 800-228-5275 or 231-547-6584 for price and delivery. Typical lead time is four to six weeks.

## Service Life

The service life of acrylic refractors is virtually unlimited when used within the recommended temperature limit. Acrylic versions are covered by our 10 year limited warranty.

## Notice

LexaLite assumes no responsibility for suitability of luminaires and applications. The use of refractors at excessive temperatures with high UV output light sources will cause degradation of the material.



**A.L.P.**  
LIGHTING COMPONENTS, INC.  
WEB SITE: [WWW.ALPLIGHTING.COM](http://WWW.ALPLIGHTING.COM)

 **LEXALITE**

# Model 425

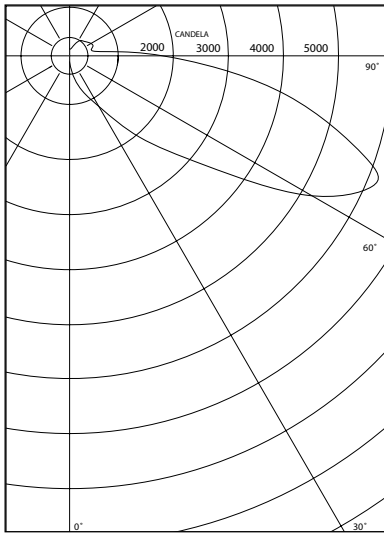

Report Number: ITL48839  
 Total Luminaire Efficiency = 83.01%  
 IES Classification: Type III, Medium, Non-Cutoff

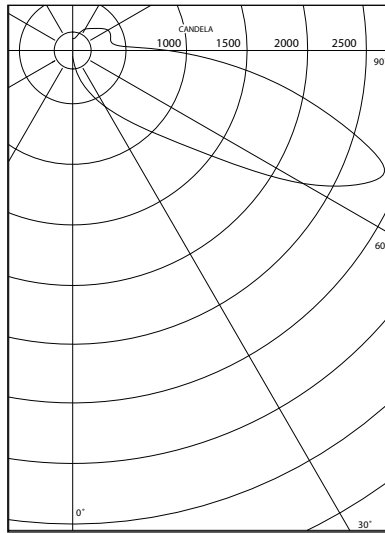

Report Number: ITL48840  
 Total Luminaire Efficiency = 83.17%  
 IES Classification: Type V, Non-Cutoff

## Photometrics

The Model 425 is available in IES Type III and Type V distributions, and will classify as medium, non-cutoff, depending upon lamp type and lamp center location. The Model 425 Type III, coupled with the perforated LiteLid, acorn top and a 175W phosphor-coated MH lamp, produces 6169 candela at 67.5° vertical and 72.7° lateral (ITL48839). The Model 425 Type V, coupled with the perforated LiteLid, acorn top and a 175W phosphor-coated MH lamp, produces 2835 candela at 67.5° vertical (ITL48840). Both the Type III and V distributions are optimized with diffuse HPS and coated MH lamps. Use of clear lamps may result in reduced uniformity. Individual luminaire performance depends on the lamp center position and the reflector design chosen. Each luminaire design should be individually tested for proper classification. Please call for additional photometric data. Design light center is located 3.0" down from upper rim.

## Accessories

**LiteLid®** LiteLids should be utilized in light pollution-sensitive areas to redirect potentially wasted uplight into increased downward efficiencies. The LiteLid® allows just enough uplight for a pleasing glow. LiteLids are patented, aluminum reflectors which fit between the top and bottom components.

**4245P** Perforated LiteLid

**4245N** Non-perforated LiteLid

**Stainless Steel Clamp Band** For attachment of top.

**Neck Ring** Protects fitter from metal screws.

## Materials

Clear acrylic: Molded in Underwriters Laboratory (UL) recognized Altuglas International Plexiglas® V-825-HID, Lucite International Inc. Perspex® CP-75-HID, Plaskolite Optix® CA-75HID or CYRO Acrylite® S-10-453.

Acrylic Moon Glow white: Molded in a PMMA resin with a customized pigment additive.

Clear polycarbonate: Molded in UL recognized Bayer lighting grade polycarbonates including Makrolon® LTG 3123, Makrolon® LTG 2623, or GE Lexan® grade 243. LexaLite's proprietary treatment to retard yellowing in ultraviolet environments, UvaLex®, is optional on these polycarbonate refractors.

Please visit our web site for the most current material specifications. When using an acrylic Model 425, the surface temperature of the refractor should not exceed 80°C. When using a polycarbonate Model 425, the surface temperature of the refractor should not exceed 90°C.

